



DUPLEX NEMA1 INDOOR PANEL

D10020N1 SINGLE PHASE CONTROL PANEL

APPLICATIONS

Superior quality duplex liquid level controller, automatic alternation for two pump operation. High level alarm warning designed for a variety of sump, effluent, sewage and water transfer applications. Not for use in damp, outdoor or weatherproof applications.

SPECIFICATIONS

- Non-modifiable – No options available.
- Accepts single or dual power feed.
- Two hand-off-automatic (H-O-A) pump switches.
- On-off control circuit switch.
- Two oversized magnetic contactors.
- Numbered terminal strip-screw type.
- NEMA 1, 30 watt, flashing red light.
- NEMA 1, steel enclosure.
- NEMA 1, alarm horn - 95db.
- Auxiliary alarm contacts.
- Alternator selector switch
- Lag pump start delay

Single Phase

- Field adjustable for 115 or 230 V, 60 Hz.
- Two pump 25 amp circuit breakers.
- Enclosure: 12.3" W x 14.3" H x 6" D.

NOTE: Enclosure dimensions do not include 3" high light.

PANEL MODEL INFORMATION

ORDER NUMBER	AMP RANGE
D10020N1	0-20

Panel is non-modifiable.

FEATURES

- Provides fully automatic operation for two pumps. Alternates pump starting to distribute operating time. Provides extra pumping capacity in times of high inflow by energizing both pumps.
- Solid state pump alternator circuit with float status lights for ease of installation or trouble shooting.
- Alternator selector switch allows a choice of automatic alternation or operation of only pump 1 or pump 2. Typically used if one pump is down for maintenance.
- Lag pump start delay built-in.
- High level alarm circuit includes through door mounted silence switch for manual silence of alarm horn.
- Two through door mounted pump run lights.
- Top mounted high intensity flashing red light provides 360° visibility.
- Pulsating, corrosion proof alarm horn.
- Auxiliary alarm contacts provided for remote alarm connection.
- Lag pump start delay built-in. Delays starting lag pump for 5 seconds if both pumps attempt to start simultaneously as after a power outage.
- Color coded wiring, screw type terminals and plug in sockets, insure ease of field servicing.
- Field wiring diagram, panel schematic and installation instructions included.
- Factory wired for operation with three float switches. An easy field modification for four float switch operation using separate "lag-on" and "alarm switches" is provided.
- Panel can be wired for a single power feed for pumps and control circuit or the control circuit can be wired to a separate power supply to insure alarm integrity in case of a tripped main breaker.
- Float Switches - Note: Please order float switches separately. Requires three narrow angle switches or optional fourth float for lag pump.
- Entire unit is UL and CUL listed.

Wastewater

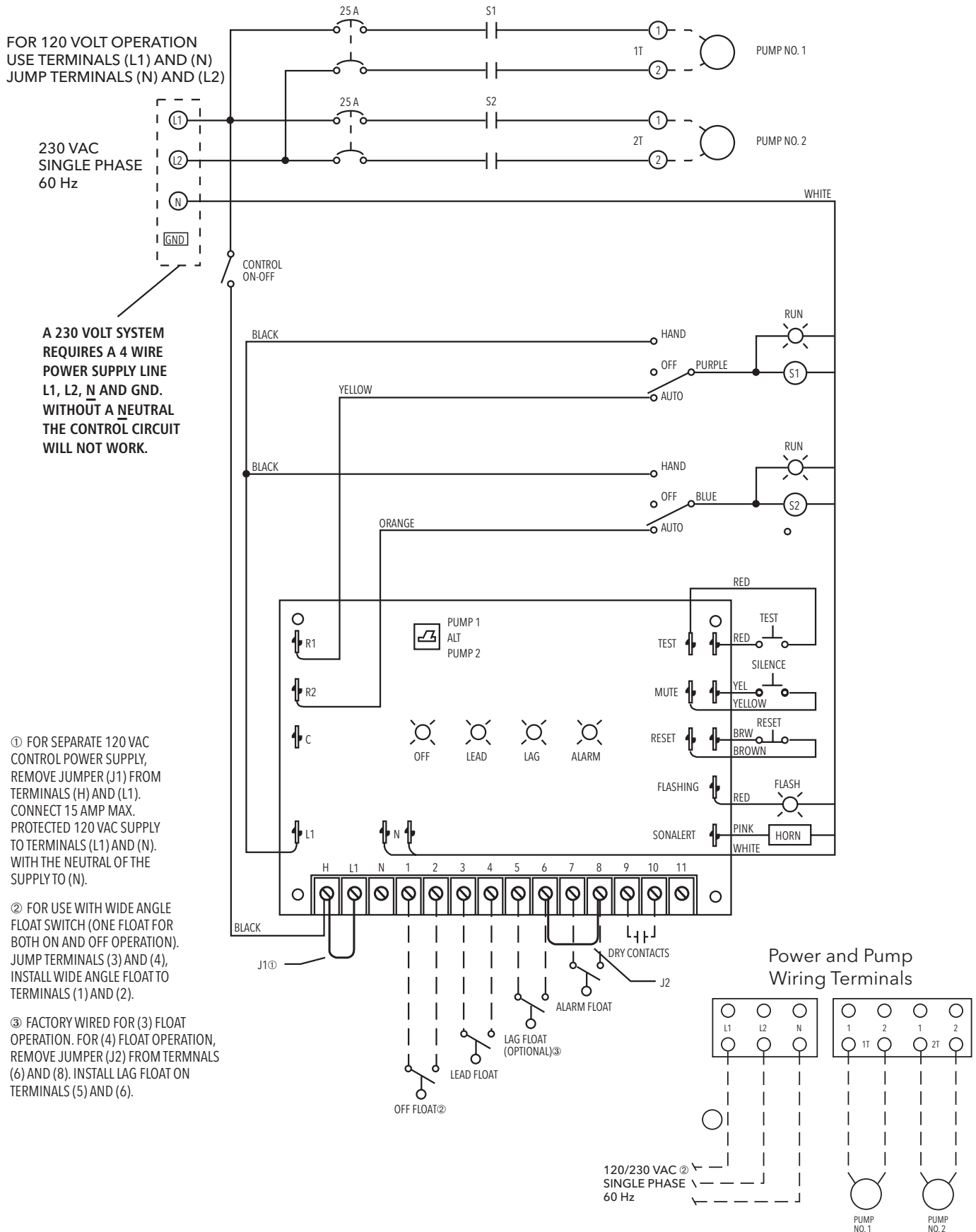

D10020N1 COMPONENTS

1. NEMA 1 enclosure
2. Flashing alarm light
3. Alarm horn
4. Pump run lights
5. Horn on/off selector switch
6. Alarm test selector switch
7. Control power on/off selector switch
8. H-O-A selector switches
9. Alarm reset selector switch
10. Contactors
11. Terminal strip
12. Terminal strip
13. Control board
14. Motor circuit breakers

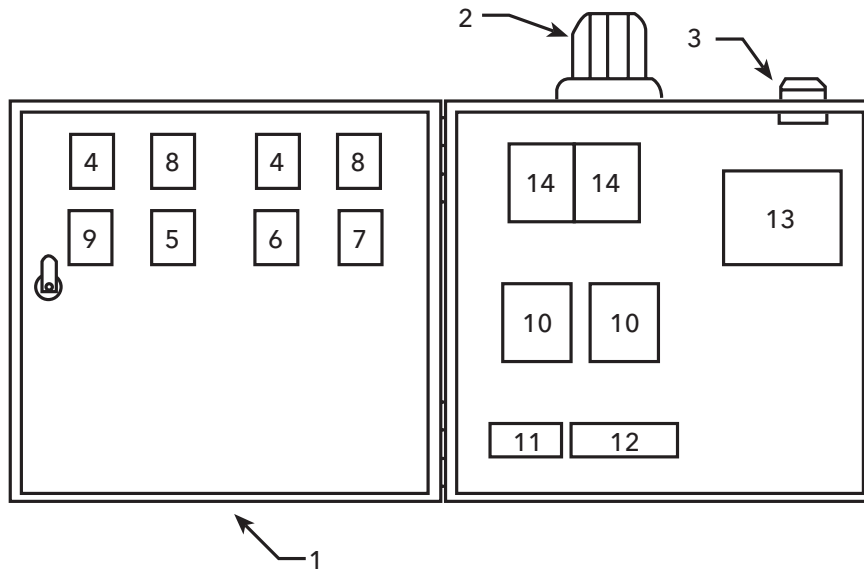

xylem
Let's Solve Water

Xylem, Inc.
2881 East Bayard Street Ext., Suite A
Seneca Falls, NY 13148
Phone: (866) 325-4210
Fax: (888) 322-5877
www.xylem.com/brands/centripro

CentriPro is a trademark of Xylem Inc. or one of its subsidiaries.
© 2012 Xylem, Inc. BCP2 R6 April 2012