

Self-Priming High Pressure Hydroseeding Pumps

Model 3HY13HR (High-Suction)

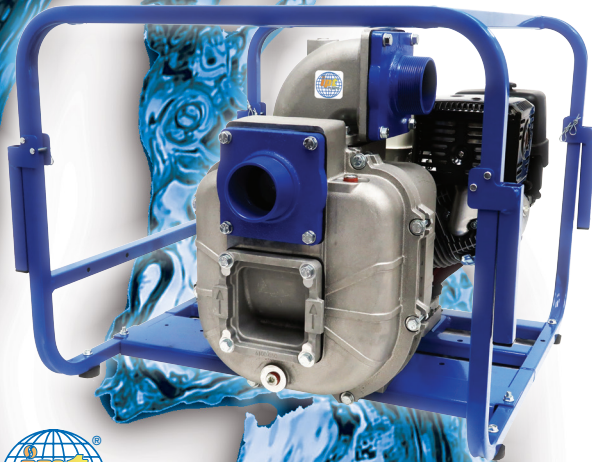

Model 3HY13HR
(Low-Suction)

The IPT line of Self-Priming High Pressure Pumps, also known as Hydroseeder Pumps, delivers both excellent pressure and flow for many applications including, but not limited to: general dewatering, agricultural spraying, hydroseeding, washdown, fire protection, and irrigation. These single stage centrifugal pumps are sand cast aluminum construction with cast iron wear parts, male NPT ports, and EPDM/EPR Elastomers. They are available with gasoline engines, offered in both 3" and 4" models, and come standard with a heavy duty steel frame, suction strainer, and designed for easy maintenance with servicing tool included.

- Sand Cast Aluminum Construction with Cast Iron Wear Parts
- EPDM/EPR Mechanical Seal, O-Rings, and Gaskets
- 3" or 4" Male NPT Cast Iron Suction & Discharge Ports
- Convertible High or Low Suction Port for Improved Efficiency Dependent on Self-Priming or Flooded Applications
- Built-In EPDM Flapper/Check Valve Permits Priming up to 20'
- Discharge Port Rotates 180° Increments
- Available with Honda E-Start Gasoline Engine
- Maximum Head up to 202' TDH (87 PSI)
- Maximum Flow up to 560 GPM
- Includes Servicing Tool, Suction Strainer, and Heavy Duty Steel Frame with Battery Tray Included

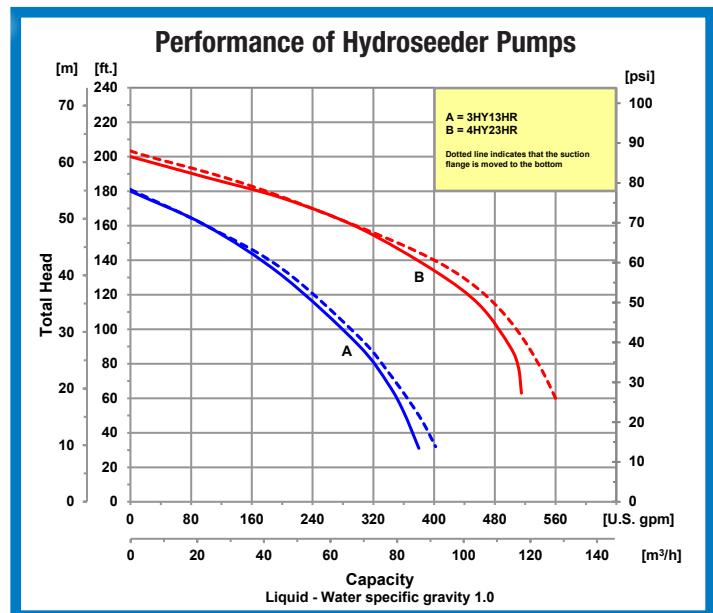

400 Spring Street • Royersford, PA 19468 USA

www.amtpump.com • 888-amt-pump (268-7867)

For use with nonflammable liquids compatible with pump component materials. Viton® and Teflon® are registered trademarks of E. I. DuPont.



3"-4" High Pressure Hydroseeding Pumps

Pump Dimensional & Specification Data

Model	Curve	Driver	Seal Types & Elastomers/Faces	Tank Size (Gal/Ltr)	Run Time (Hr.)	Ship Wt. (Lbs.)
3HY13HR	A	Honda GX390▲++	EPDM/CAR/CAR	1.6/6.1	2.5	175
4HY23HR	B	Honda GX690 23HP ▲++	EPDM/CAR/CAR	15/56.8	10.5	240

Construction: Cast Aluminum with Cast Iron Components
 ++ 12VDC Electric Start (Battery Not Included)
 ▲Oil Alert Included

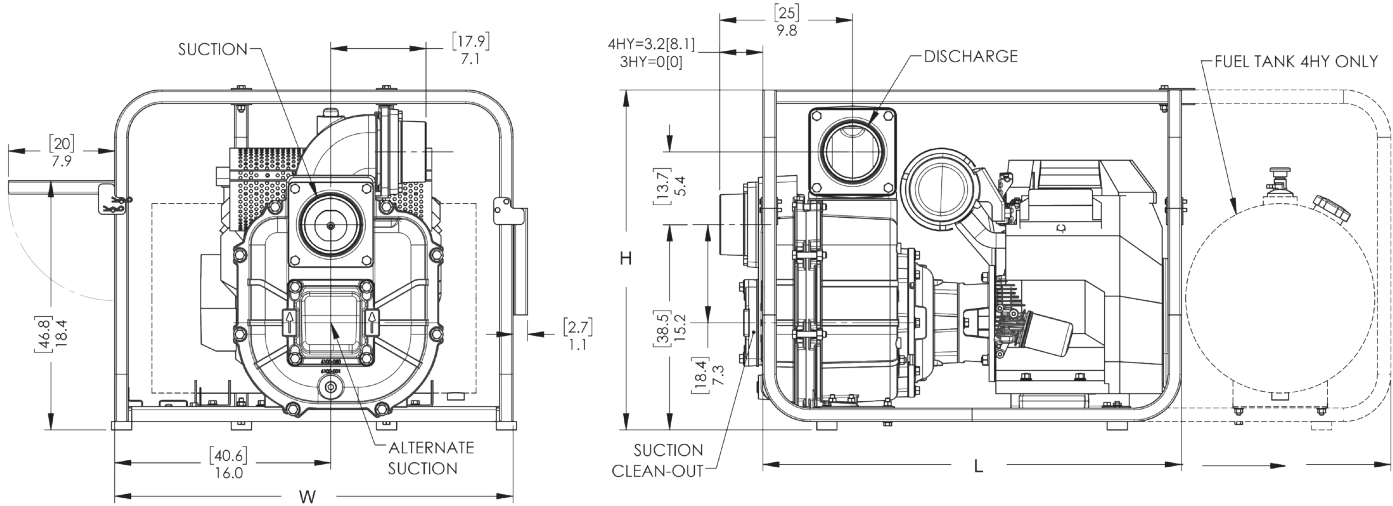

Model	HP Class ♦	SUC*	DIS*	L**	W**	H
3HY13HR	13 HP	3	3	31.0 [78.7]	29.5 [74.9]	25.1 [63.8]
4HY23HR	23 HP	4	4	49.7 [126.2]	29.5 [74.9]	25.1 [63.8]

(♦) HP Class represents market category and is not intended to define actual horsepower.
 (*) Standard NPT (Male) pipe thread
 NOTE: Dimensions are in inches (centimeters) and have a tolerance of ± 1/8".
 (†) Minimal Assembly Required: Auxiliary Fuel Tank Shipped Uninstalled.

Standard Features

- Aluminum Construction with Cast Iron Wear Parts
- EPDM/EPR Mechanical Seal with Carbon & Carbide Faces
- 3" or 4" Models Available with Honda Gasoline E-Start Engine
- Male NPT Discharge Port Rotates in 180° Increments to the left or right
- Convertible Suction Port in High/Low position for Improved Performance and Efficiency
- Built-In EPDM Flapper/Check Valve Permits Priming up to 20' with High Suction Setup
- Design Permits Easy Clean-Out and Servicing and Includes Servicing Tool
- Max Solids Handling
 - 3" Models up to 5/8"
 - 4" Models up to 1"
- Maximum Temperature 180°
- Heavy Duty Steel Roll Frame with Battery Tray Included
- Optional High Pressure Hose Kit or Wheel Kit Available



Manufacturer of AMT & IPT Pumps

400 Spring Street • Royersford, PA 19468 USA

www.amtpump.com • 888-amt-pump (268-7867)

The Gorman-Rupp Company reserves the right to discontinue any model or change specifications at any time without incurring any obligation.
 ©2012 American Machine and Tool Company. All rights reserved.



GORMAN-RUPP®

0424