

100H, 150H, 225H, 275H

60 Hz High Capacity 6" Submersible Pumps

For 6" and larger wells

FEATURES

Powered for Continuous Operation: All ratings are within the working limits of the motor manufacturer. Pump can be operated continuously without fear of damage to the motor.

Completely Field Serviceable: Easy to install and service. All parts easily dismantled if field service is ever necessary. No special tools needed. No shipping back to factory.

Diverse Application: Designed for commercial, municipal and agricultural water needs.

Bearings: Replaceable fluted bearings allow excellent abrasives handling and wear resistance.

Shaft Sleeves: Replaceable stainless steel, hex-driven, sleeves help protect shaft from abrasives.

Pump Shaft: Precision straightened hex shaft.

Coupling: Heavy duty stainless steel, splined coupling for maximum load-carrying capability.

Bowls: Cast iron turbine bowl design.

Impellers: Silicon brass impellers dynamically balanced for smooth operation.

Suction Strainer: Stainless steel strainer restricts gravel and other debris from entering the pump.

Cable Guard: Stainless steel cable guard surrounds and protects motor leads.

Fasteners: All fasteners are stainless steel.

NEMA Design Motors: Stainless steel and epoxy coated end bells resist corrosion. Water filled design provides a constant supply of lubrication. Hermetically sealed stator assures moisture free windings. Durable Kingsbury type thrust bearing absorbs all thrust. Replaceable motor lead assembly.



SPECIFICATIONS

Model	Horsepower Range	Discharge Connection	Recommended GPM Operating Range	GPM at Best Efficiency	Minimum Well Size	Rotation ^①
100H	5 – 25	3" NPT	45 – 160	100	6"	CCW
150H	5 – 25	3" NPT	50 – 240	150	6"	CCW
225H	5 – 30	3" NPT	80 – 360	225	6"	CCW
275H	10 – 25	3" NPT	80 – 440	275	6"	CW ^②
	30 – 40	4" NPT				

① Rotation when viewed from pump discharge end.

② The 275H has clockwise rotation. It can only be used with three (3) phase motors.

SYSTEM COMPONENTS

- **Pump/Water End:**
 - 6" Pump.
 - 4" Motor Adapter on 3 and 5 HP models.
 - 6" Motor Adapter on 7.5 HP and larger models.
- **Motor:**
 - 4" Motor required for 3 HP and 5 HP pumps.
 - 6" Motor required for 7.5 HP and larger pumps.
- **Control Box:** Required for all single phase motors.
- **Magnetic Starter:** A magnetic starter with overloads is required for all three phase units.

PUMPS, MOTORS AND CONTROLS MUST BE ORDERED SEPARATELY AND ARE PACKAGED SEPARATELY.

"H" SERIES MATERIALS OF CONSTRUCTION

Part Name	Material
Motor Adapter	Cast Iron ASTM A48 Class 30
Discharge Head	
Bowl	
Shaft 2–6 Stage	ASTM A276 AISI T304 SS
Shaft 7–13 Stage	Monel ASTM B164
Coupling	ASTM A582 AISI T303 SS
Spline Protector	Neoprene
Suction Screen	ASTM A582 AISI T303 SS
Shaft Sleeve	AISI T316 SS Powder Metal
Bearing	Viton®
Impeller	ASTM B584 C87610
Cotter Pin	ASTM A276 AISI T304 SS
Wear Ring	ASTM C95400
Hex Head Bolts	ASTM F593 AISI T303 SS
Cable Guard	ASTM A582 AISI T303 SS
Lock Washers	ASTM A582 AISI T303 SS

ORDER NUMBER CODE

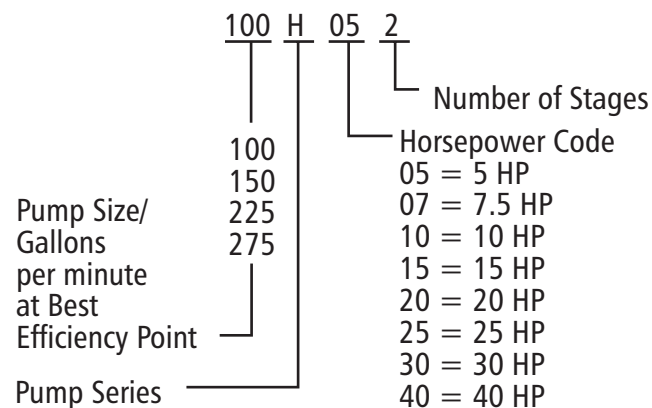

WATER END (PUMP) DATA

Series	Order No.	Stages	Required Motor		Water End	
			HP	Diameter	Length	Weight (lb)
100H	100H05 2	2	5	4"	18.0	51
	100H07 4	4	7.5	6"	29.3	84
	100H10 5	5	10	6"	34.3	105
	100H15 8	8	15	6"	49.3	154
	100H20 10	10	20	6"	59.3	185
	100H25 13	13	25	6"	74.3	258
150H	150H05 2	2	5	4"	18.0	51
	150H07 3	3	7.5	6"	24.3	73
	150H10 4	4	10	6"	29.3	84
	150H15 6	6	15	6"	39.3	136
	150H20 8	8	20	6"	49.3	154
	150H25 10	10	25	6"	59.3	185
225H	225H05 2	2	5	4"	18.0	51
	225H07 2	2	7.5	6"	18.0	51
	225H10 3	3	10	6"	24.3	73
	225H15 4	4	15	6"	29.3	84
	225H20 6	6	20	6"	39.3	136
	225H25 7	7	25	6"	44.3	139
	225H30 8	8	30	6"	49.3	154
	225H30 9	9	30	6"	54.3	172
275H *	275H10 2	2	10	6"	19.3	51
	275H15 3	3	15	6"	24.3	73
	275H20 4	4	20	6"	29.3	84
	275H25 5	5	25	6"	34.3	105
	275H30 6	6	30	6"	39.3	136
	275H30 7	7	30	6"	44.3	139
	275H40 8	8	40	6"	49.3	154
	275H40 9	9	40	6"	54.3	172

* The 275H rotates Clockwise when viewed from the the top of the pump, therefore, it may only be used with three-phase motors running clockwise. Single-phase motors rotate CCW.

WATER END (PUMP) DATA

NOTE: 4" Diameter motors are required for 3 and 5 HP "H" Series pumps
 6" Diameter motors are required for 7.5 HP and larger "H" Series pumps.

CentriPro Motors

Single Phase Motors – Dimensions and Weights					
Motor Order No.	HP	Motor Diameter	Volts	Length (inches)	Weight (lbs)
M50412	5	4"	230	27.7	70
6M071	7.5	6"	230	29.9	128
6M101	10			33.5	148
6M151	15				
Three Phase Motors – Dimensions and Weights					
M50432	5	4"	230	21.7	55
M50434			460		
6M072	7.5	6"	230	24.8	99
6M074			460		
6M102	10	6"	230	27.0	110
6M104			460		
6M152	15	6"	230	29.9	128
6M154			460		
6M202	20	6"	230	31.5	137
6M204			460		
6M252	25	6"	230	36.2	161
6M254			460		
6M302	30	6"	230	38.2	176
6M304			460		
6M404	40	6"	460	40.6	187

• 200V, 6" motors are now offered, call for availability

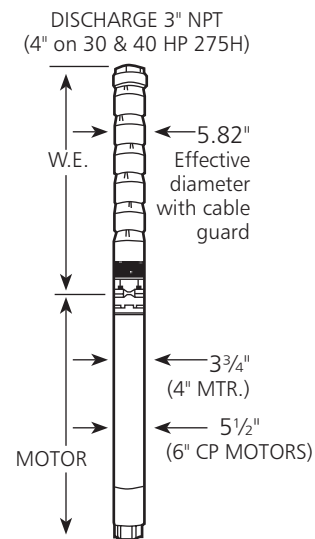

Model 100H

SELECTION CHART

Horsepower Range 5 – 25, Recommended Range 45 – 160 GPM, 60 Hz, 3450 RPM

Pump Model	Depth to Water in Feet/Ratings in GPM (Gallons per Minute)																				
	HP	PSI	25	50	75	100	125	150	175	200	250	300	350	400	450	500	600	700	800		
100H05 2 2 Stages	5	0		165	140	115	83														
		20	145	119	90																
		30	120	90																	
		40	95																		
		50																			
		60																			
100H07 4 4 Stages	7.5	0				160	150	140	127	112	65										
		20			153	140	130	113	97	68											
		30		153	140	130	113	99	70												
		40	155	143	132	118	103	72													
		50	145	132	118	103	72														
		60	133	118	104	78															
100H10 5 5 Stages	10	0				171	164	156	147	138	116	92									
		20		172	165	157	149	140	129	119	95	50									
		30	172	166	158	150	140	130	119	108	76										
		40	166	158	150	141	131	120	109	96	52										
		50	159	151	141	132	121	110	97	80											
		60	151	143	132	122	110	99	81	60											
100H15 8 8 Stages	15	0									152	139	127	112	93	68					
		20							158	152	140	128	113	95	72						
		30						158	152	147	134	120	105	85							
		40				158	153	148	142	128	113	97	73								
		50			158	153	148	143	135	122	107	88									
		60		158	153	148	143	136	129	115	98	73									
100H20 10 10 Stages	20	0							174	171	163	156	147	137	127	117	90				
		20				175	171	168	164	156	148	138	128	117	105	75					
		30			175	172	168	165	160	152	143	133	123	112	99	65					
		40		175	172	169	165	161	157	148	139	129	118	106	92	51					
		50	175	172	169	165	161	157	153	144	135	124	113	100	85						
		60	175	172	169	165	161	157	153	149	140	130	119	107	93	78					
100H25 13 13 Stages	25	0								172	167	161	155	148	140	125	107	86			
		20							175	172	167	161	155	148	141	133	117	99	73		
		30						175	172	170	164	158	152	145	137	130	113	94	63		
		40				175	173	170	168	162	156	149	142	134	126	109	88	52			
		50			175	173	170	168	165	159	153	146	138	130	122	105	82				
		60		175	173	170	168	165	162	156	150	142	135	126	118	100	75				

Model 150H

SELECTION CHART

Horsepower Range 5 – 25, Recommended Range 50 – 240 GPM, 60 Hz, 3450 RPM

Pump Model	Depth to Water in Feet/Ratings in GPM (Gallons per Minute)																	
	HP	PSI	25	50	75	100	125	150	175	200	250	300	350	400	450	500	600	
150H05 2 2 Stages	5	0	254	230	200	164	102											
		20	206	172	120													
		30	174	122														
		40	126															
		50																
		60																
150H07 3 3 Stages	7.5	0		250	234	215	192	164	126									
		20	237	220	194	170	130	78										
		30	220	197	174	134	78											
		40	200	174	140	84												
		50	176	142	90													
		60	144	100														
150H10 4 4 Stages	10	0			251	238	223	205	186	163	92							
		20	253	240	225	210	190	168	140	104								
		30	240	226	210	190	170	140	104									
		40	228	212	193	172	146	108										
		50	213	193	172	147	111											
		60	194	176	148	116												
150H15 6 6 Stages	15	0				255	246	236	226	216	192	164	122					
		20		257	248	238	228	218	206	194	167	128						
		30	258	248	238	228	218	206	194	181	150	100						
		40	248	240	230	220	208	196	184	168	130							
		50	240	230	220	209	196	184	170	154	107							
		60	234	220	210	198	185	172	154	136	78							
150H20 8 8 Stages	20	0					259	252	244	237	221	204	183	163	134	95		
		20			260	253	246	238	230	223	206	187	166	138	100			
		30		260	253	246	239	231	223	214	197	177	154	120				
		40		254	247	240	232	224	216	208	188	168	140	102				
		50	255	247	240	232	224	216	208	199	180	156	125	80				
		60	247	240	232	225	216	209	199	190	170	142	106					
150H25 10 10 Stages	25	0							258	252	240	226	212	198	182	165	113	
		20						259	253	247	240	227	213	199	183	166	144	78
		30				260	253	247	240	234	220	207	192	175	156	132	100	
		40			260	254	247	241	234	228	214	200	184	168	146	118		
		50		260	254	248	242	235	229	222	208	193	177	158	134	104		
		60	260	254	248	242	235	230	222	216	201	186	169	148	120	84		

Residential Water Systems

Model 225H

SELECTION CHART

Horsepower Range 5 – 30, Recommended Range 80 – 360 GPM, 60 Hz, 3450 RPM

Pump Model	Depth to Water in Feet/Ratings in GPM (Gallons per Minute)																
	HP	PSI	25	50	75	100	125	150	175	200	250	300	350	400	450	500	
225H05 2 2 Stages	5	0	230	282	220	100											
		20	236	136													
		30	140														
		40															
		50															
		60															
225H07 2 2 Stages	7.5	0		320	270	210											
		20	280	222	120												
		30	226	116													
		40	136														
		50															
		60															
225H10 3 3 Stages	10	0		350	320	285	250	210	140								
		20	324	292	258	216	154										
		30	294	260	220	160											
		40	262	230	166												
		50	226	174													
		60	178														
225H15 4 4 Stages	15	0			334	320	296	272	242	210							
		20	350	326	302	276	250	216	276								
		30	326	302	277	251	220	180									
		40	304	280	252	222	182										
		50	282	258	224	186											
		60	258	226	192												
225H20 6 6 Stages	20	0				352	336	320	304	287	251	207	130				
		20		354	340	324	307	290	273	254	212	140					
		30	355	340	325	308	292	274	254	236	184						
		40	341	326	309	293	275	257	236	215	148						
		50	326	310	294	276	258	238	216	190							
		60	312	295	278	260	240	220	194	156							
225H25 7 7 Stages	25	0				360	348	334	320	306	277	245	208	150			
		20			350	336	322	308	294	280	248	212	158				
		30		351	327	324	310	296	281	264	232	190	110				
		40	350	340	324	311	296	282	266	250	212	164	116				
		50	340	324	312	296	282	266	252	234	196	120					
		60	327	312	298	284	269	252	236	218	168						
225H30 8 8 Stages	30	0					356	344	332	320	296	270	242	208	162		
		20			358	346	334	322	310	300	272	244	212	168			
		30		358	347	335	323	311	300	286	260	230	194	131			
		40	360	348	336	324	312	300	287	274	246	214	172				
		50	349	337	326	313	301	288	275	262	232	197	140				
		60	338	326	314	302	290	276	262	248	218	176					
225H30 9 9 Stages	30	0					352	342	332	311	289	265	240	209	167		
		20				354	344	334	324	313	291	268	242	212	172	92	
		30			354	344	334	324	313	302	280	256	228	194	144		
		40		356	346	336	325	314	303	292	269	244	214	176	102		
		50	356	346	336	326	315	304	294	282	258	230	198	150			
		60	347	337	326	316	306	294	282	270	244	216	178	110			

Residential Water Systems

Model 275H

SELECTION CHART

Horsepower Range 10 – 40, Recommended Range 80 – 440 GPM, 60 Hz, 3450 RPM

Pump Model	Depth to Water in Feet/Ratings in GPM (Gallons per Minute)																
	HP	PSI	25	50	75	100	125	150	175	200	250	300	350	400	450	500	
275H10 2 Stages	10	0		425	356	255	108										
		20	370	283	135												
		30	293	140													
		40	145														
		50															
		60															
275H15 3 Stages	15	0			416	375	325	248	140								
		20	423	383	335	268	158										
		30	385	338	270	160											
		40	343	283	170												
		50	288	175													
		60	178														
275H20 4 Stages	20	0				419	385	350	308	248	78						
		20		435	393	355	315	263	180	96							
		30	425	392	356	315	263	183	103								
		40	395	363	323	273	185	118									
		50	363	326	275	195	120										
		60	325	268	200	123											
275H25 5 Stages	25	0				448	423	398	370	338	250	115					
		20		448	433	403	375	343	310	265	130						
		30	450	428	405	376	345	313	267	195							
		40	430	407	378	345	313	267	196								
		50	410	380	345	313	268	203									
		60	382	345	314	269	206										
275H30 6 Stages	30	0					441	421	400	375	325	250	135				
		20			446	425	403	378	356	330	257	145					
		30		447	427	405	380	358	331	300	198						
		40	448	428	406	382	360	332	302	268	160						
		50	430	407	383	363	334	304	270	210							
		60	408	385	365	335	305	273	211								
275H30 7 Stages	30	0						439	420	403	363	315	250	165			
		20				442	425	405	388	368	320	258	183	78			
		30			443	426	405	389	368	345	293	215	132				
		40		444	427	406	390	369	347	323	265	180	90				
		50	445	428	407	391	369	348	324	300	223	143					
		60	430	408	392	370	350	325	300	265	183	90					
275H40 8 Stages	40	0							436	421	387	353	311	250	175	95	
		20					440	425	408	392	356	346	258	183	105		
		30					440	425	409	393	375	338	290	220	150		
		40			441	426	410	394	376	359	318	262	188	113			
		50		442	427	412	395	377	360	341	300	225	158				
		60	443	428	413	396	378	361	341	321	268	190	118				
275H40 9 Stages	40	0							448	435	407	376	338	303	249	180	
		20					450	435	423	410	378	342	307	342	185	122	
		30					449	438	423	411	395	365	332	285	253	155	80
		40			448	439	424	413	396	381	350	310	260	193	125		
		50		447	440	425	414	396	382	366	333	288	225	163	86		
		60	446	440	425	415	397	383	367	350	313	263	193	128			

USE ONLY WITH 3 PHASE MOTORS. ROTATION IS DIFFERENT THAN 1 PHASE MOTORS.

Model 100H

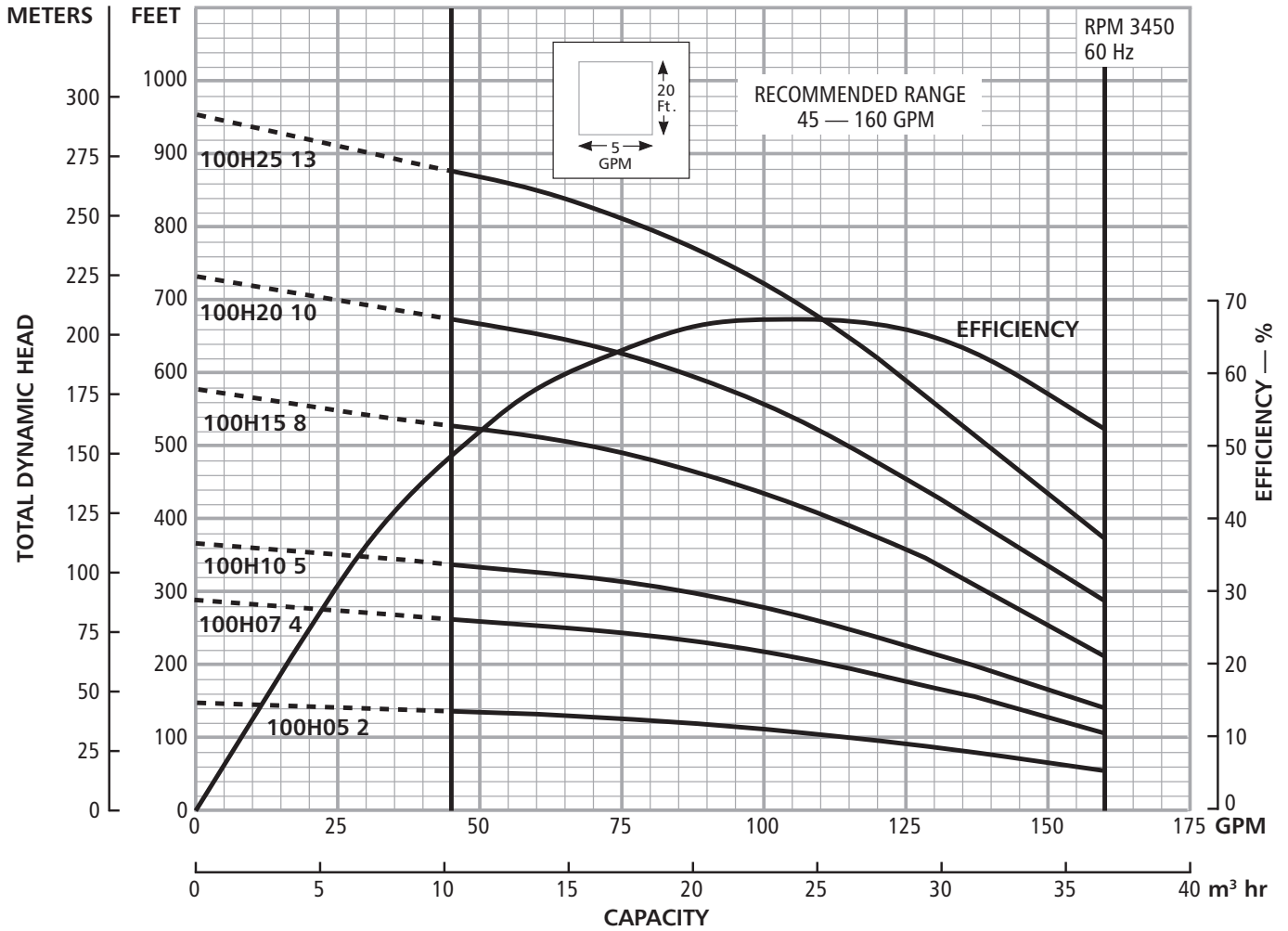

Curve Reference SU 0021RO

Model 150H

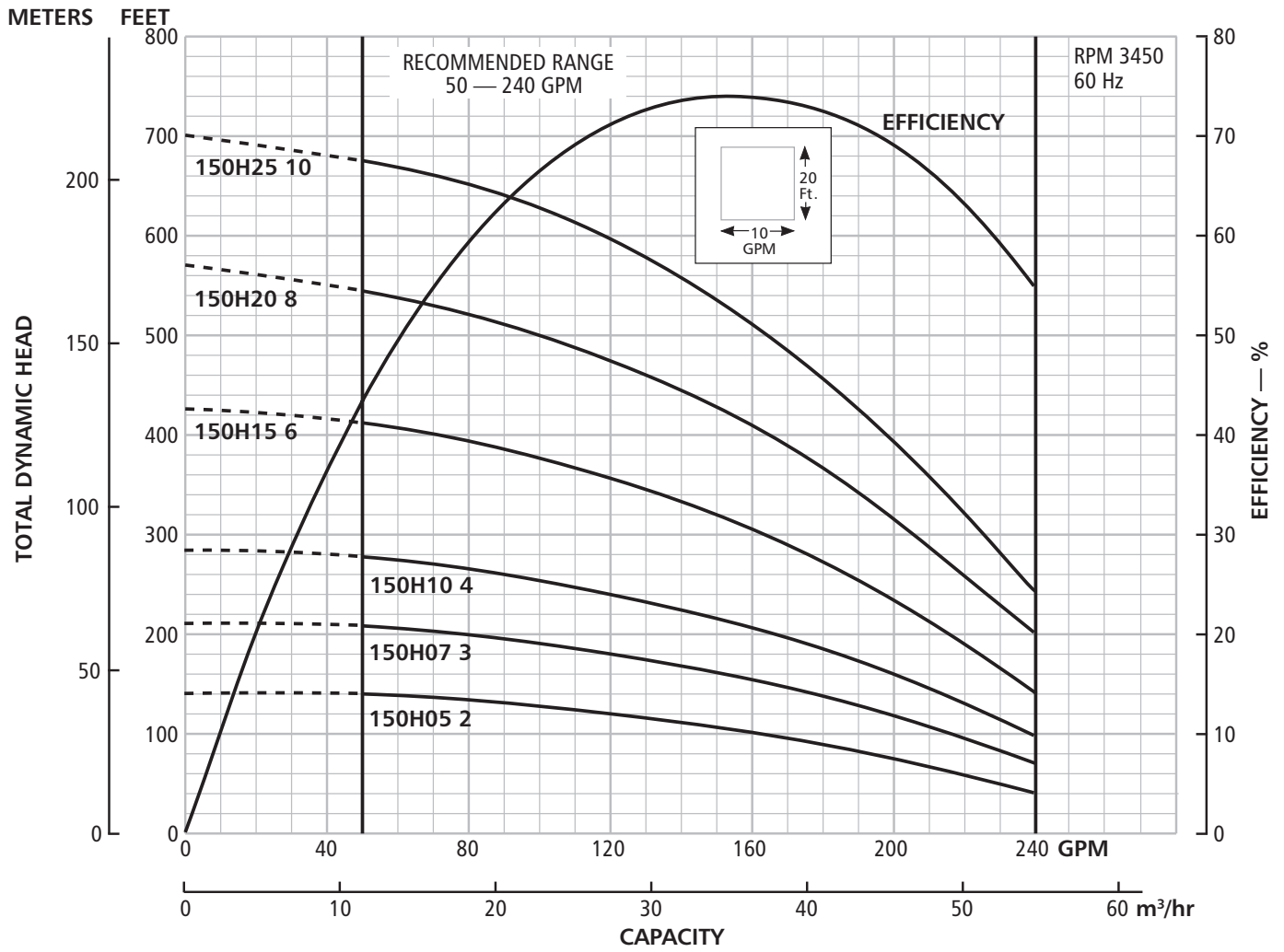

Curve Reference SU 507

Model 225H

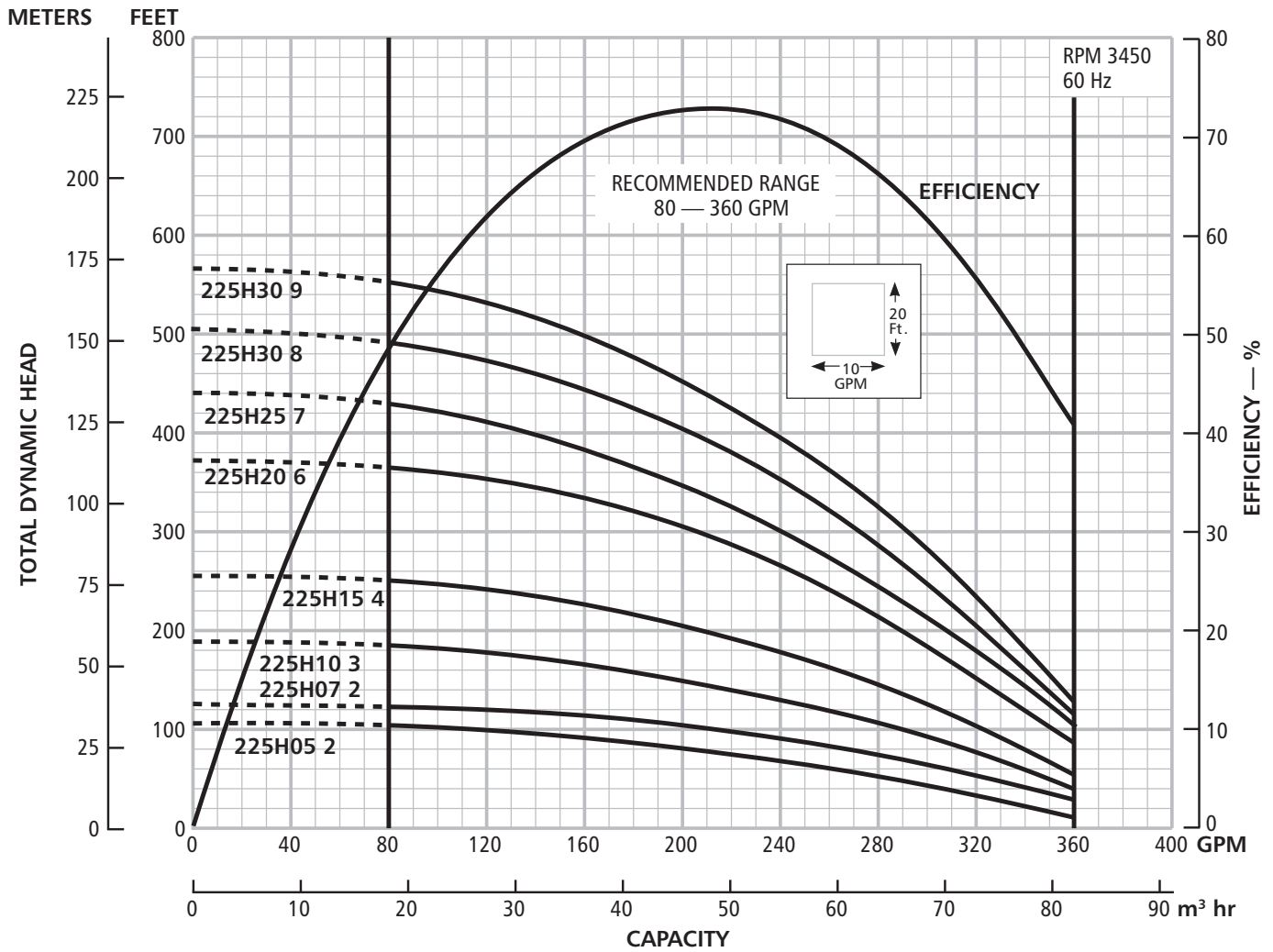

Curve Reference SU 508

Model 275H

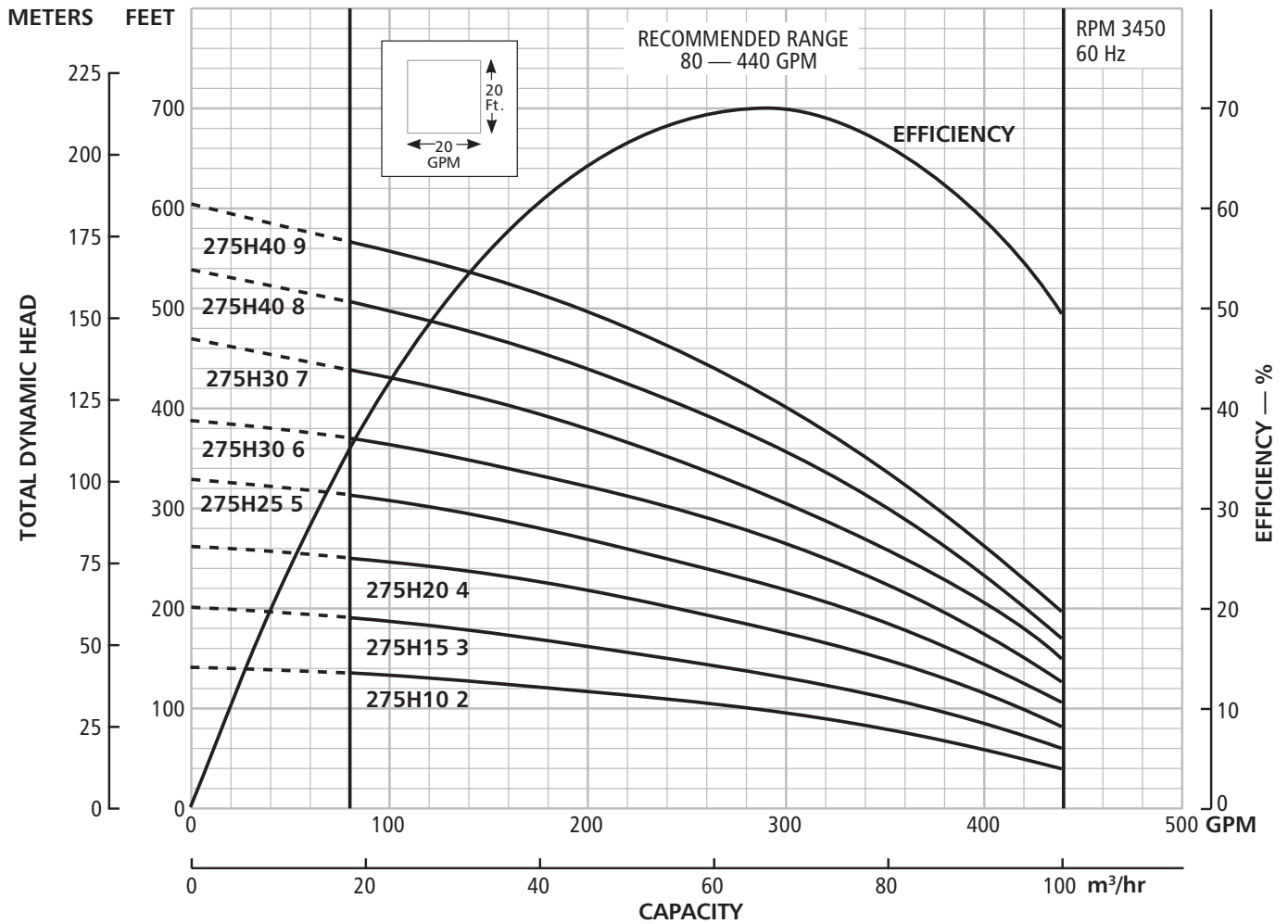

Three Phase Only, due to required CW Rotation.

Curve Reference SU 484